

Bencros BTK Block Fenders, traditionally called keyhole fenders, are moulded rubber units mostly used on the bows and sterns of tugs, providing robust, heavy-duty protection.

BTK Blocks are also popular for pontoons and RoRo ramp ends. They are mounted via steel pins inserted through the twin holes which allows for easy installation and replacement.

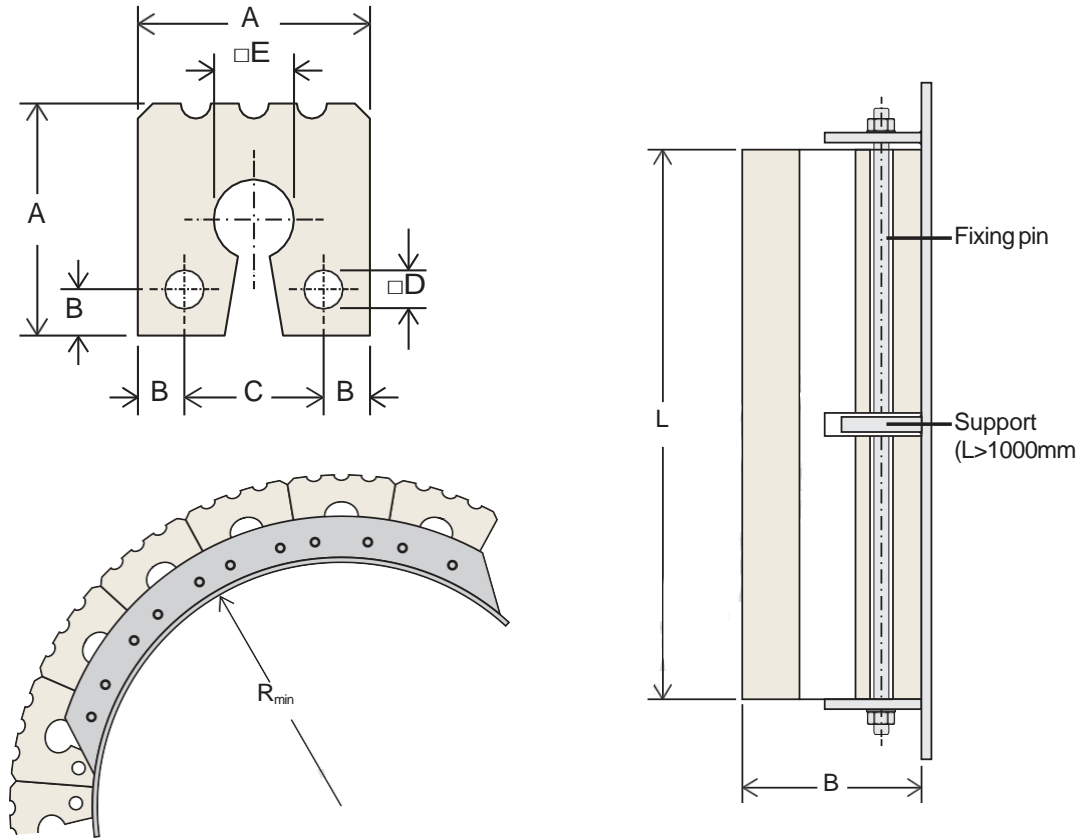

Type	A	B	C	ØD	E	F	ØG	LMAX	Flat Bar	R(min)	Weight
BTK-200	200	200	35	28	35	130	90	2000	100 x 15	450	33
BTK-250	250	250	50	33	50	150	100	2000	125 x 20	600	54
BTK-300	300	300	60	33	60	180	115	1750	150 x 20	800	80
BTK-350	350	350	70	33	70	210	125	2000	175 x 25	1000	114

Performance tolerance is $\pm 20\%$.

Reaction is per square metre of flat fender area and for Bencros C1 (standard) rubber grade.

Dimensions are in millimetres.

Weights are in kilogrammes per metre length.

For other sizes, fixing details and custom features, please ask Bencros.

